

The New Standard in Outdoor High Power Redundant  
 Microwave Amplifier Systems Has Arrived

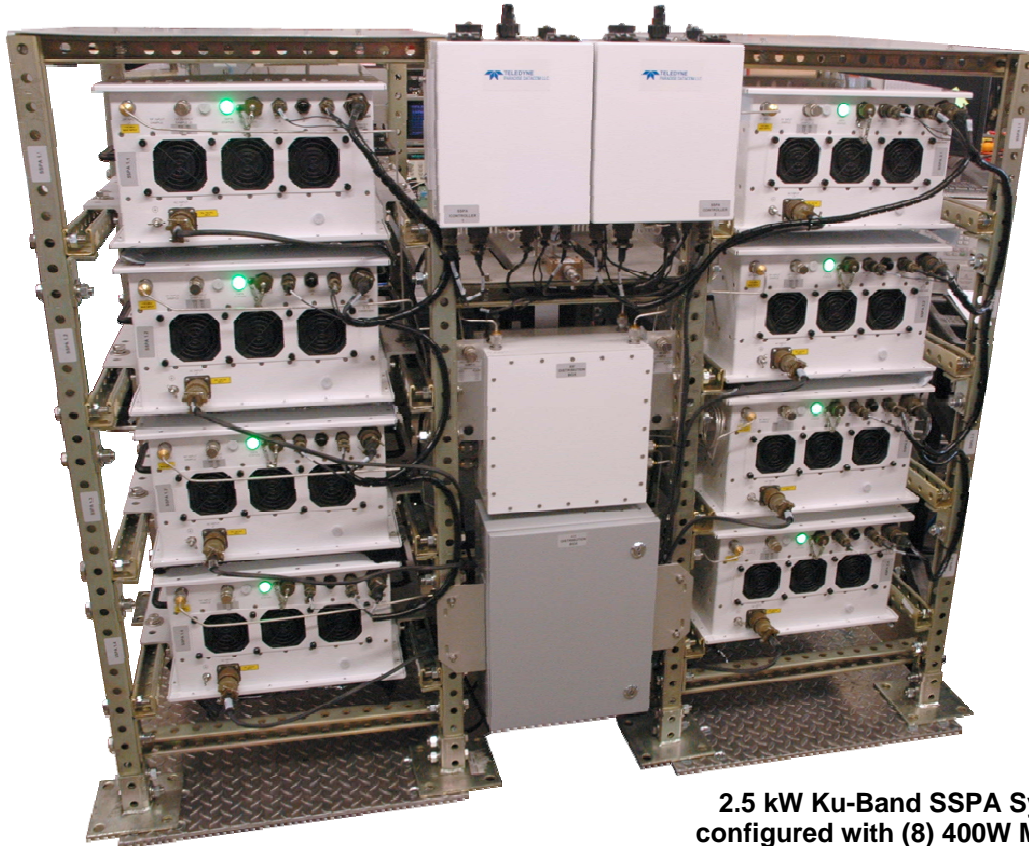

**2.5 kW Ku-Band SSPA System  
 configured with (8) 400W Modules**

### FEATURES

- Gallium Nitride amplifiers, offering higher power density
- Output Power levels of up to:
  - 10 kW in S-, C-, X-Bands;
  - 5.8 kW in Ku-Band
- Each array of 4 HPAs features no active switching - all passive Power Combining
- Output Power sized for N+1 Redundancy
- System can be configured with any combination of 4 to 16 units
- Removable fan trays
- System is 100% field maintainable
- System Monitor and Control emulates single SSPA Chassis operation
- Legacy RS-485 M&C
- Ethernet Port with UDP, SNMP, and internal web browser capability
- Accurate Output Power measurement
- Reflected Power Monitor
- Optional L-Band Input with Redundancy
- RF Output Sample Port
- RF Gain Adjustment (42 dB - 62 dB) Ku-Band systems (50 dB - 70 dB) all others
- System is field scalable: i.e., can start out with (4) modules in system and upgrade to (8) or (16) modules.

PowerMAX is covered by U.S. Patent Nos. 8,189,338 B2 and 8,411,477 B2

### System Operation

The Outdoor PowerMAX system maintains complete parallel redundancy down to the embedded control level. Therefore the loss of an entire amplifier will not interrupt remote communications with the system. Remote communications can be either RS-485 or Ethernet. The system will automatically correct its gain level in the event of one or more amplifier failures.

The sophisticated system monitor and control allows the system to be locally or remotely operated as if it were a “single” chassis amplifier. The system control maintains a hierarchical management that allows the operator to interface to a single chassis of the multi-module array.

Another feature unique to Teledyne Paradise Datacom’s Outdoor PowerMAX is the introduction of “true rms” output power measurement. Unlike other amplifier systems that utilize diode detection schemes, the Outdoor PowerMAX reports the true rms output power of the system independent of the number of carriers and modulation schemes.

Proprietary waveguide combining techniques are employed so that maximum power combining efficiency is optimized within the operating frequency band.

### System Output Power and Configurations

The Outdoor PowerMAX system is typically used as a “self-redundant” system. The output power is sized such that the loss of (1) RF module’s power will still allow the system to maintain its minimum required output power. This type of system architecture is described as n+1 redundant. The system can be configured with any number of modules, but best overall efficiency is obtained with the popular binary combinations of 4, 8, or 16 modules.

It is very easy to upgrade the PowerMAX system from 4 modules to 8 or 16 modules in the field. It is not necessary to fully populate the system at the time of initial purchase. This provides the user a path to upgrade output power capability as system requirements grow, thus keeping capital investment minimized. For sizing redundant output power capability use the following guideline to determine the output power of the system with the loss of (1) module.

4 Module System - 3 of 4 Modules Operable = 2.5 dB loss in output power capability

8 Module System - 7 of 8 Modules Operable = 1.2 dB loss in output power capability

16 Module System - 15 of 16 Modules Operable = 0.6 dB loss in output power capability

## Modular N+1 Soft-Fail Phase Combined GaN System

### Hitless Redundancy

For mission critical systems in which no power outage can be tolerated, an eight module Outdoor PowerMAX system can be operated with only four modules installed. In this way, the additional four modules can be installed without requiring the system to be powered off.

The only disadvantage of operating the eight module Outdoor PowerMAX system with four modules is the additional 3 dB loss that the four module (half-system) system experiences by going through the final hybrid combiner as shown at right. The overall output power is therefore actually 6 dB below what it would be with all eight modules present.

If the module output power is sized such that this reduction in output power can be tolerated, the system shown at right is an effective means of scaling the system from four to eight modules and maintaining true hitless operation.

With parallel system architectures, the amplifier output power capability and gain will change as the number of active modules vary. The Outdoor PowerMAX system is designed with an Auto-Gain Control mode so that the overall system gain will remain constant in the event of a single module failure. See the table below.

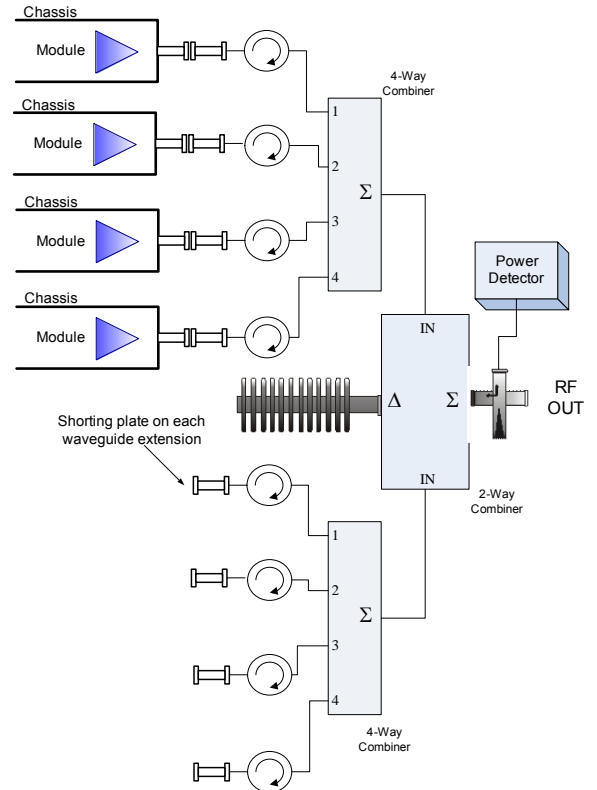

System Type	# Modules in System	Gain Change Auto Gain Control On	Gain Change Auto Gain Control Off	Maximum Output Power
4 Units	3 of 4	0 dB	-2.5 dB	-2.5 dB
4 Units	2 of 4	-1.0 dB	-6.0 dB	-6.0 dB
4 Units	1 of 4	-7.0 dB	-12.0 dB	-12.0 dB
8 Units	7 of 8	0 dB	-1.2 dB	-1.2 dB
8 Units	6 of 8	0 dB	-2.4 dB	-2.4 dB
8 Units	5 of 8	0 dB	-4.0 dB	-4.0 dB
8 Units	4 of 8	-1.0 dB	-6.0 dB	-6.0 dB
8 Units	3 of 8	-3.5 dB	-8.5 dB	-8.5 dB
8 Units	2 of 8	-7.5 dB	-12.5 dB	-12.5 dB
16 Units	15 of 16	0 dB	-0.6 dB	-0.6 dB
16 Units	14 of 16	0 dB	-1.2 dB	-1.2 dB
16 Units	13 of 16	0 dB	-2.0 dB	-2.0 dB
16 Units	12 of 16	0 dB	-2.5 dB	-2.5 dB

### SSPA Module Population Options

The Outdoor PowerMAX system is available in a variety of system GaN module configurations and output power levels. The system is based on Teledyne Paradise Datacom's High Power Outdoor SSPA. The units can be configured with a wide variety of SSPA frequency bands and power levels, and can be fitted with the following SSPA modules:

- **S-Band:** 600W, 800W, 1000W
- **C-Band:** 650W, 800W
- **X-Band:** 650W, 800W
- **Ku Band:** 300W, 400W, 500W



Hot Swappable Air Exhaust Fan Trays (2x)

Hot Swappable Air Intake Fan Tray

### Single Unit Mechanical & Environmental Specifications

PARAMETER	NOTES	LIMITS	UNITS
Size	width X length X height	16.5 X 27.5 X 9.335 419 X 699 X 238	inches mm
Weight		100 (45.5)	lbs. (kg)
Finish		powder coat	white
Operating Temperature	Ambient	-40 to +60	°C
Relative Humidity	Condensing	100	%
Cooling System	Integrated	Forced air	
Ingress Protection Rating	With connectors properly sealed	IP54	
Altitude	No temperature de-rating up to 10,000 ft. (3,000 m) De-rate maximum temperature by 2 °C per 1,000 ft (300 m) beyond 10,000 ft.		
Shock	50 g p-p, 11 msec pulses		
Vibration	3g rms 30 min. 5-2000 Hz		

## Modular N+1 Soft-Fail Phase Combined GaN System

### 4 Module S-Band Outdoor PowerMAX System Power Specifications

SSPA Module Power Level	4 Module RF Output Power		AC Input Power (W)	Heat Load (Btu/hr)	3 Module Redundant RF Output Power	
	$P_{sat}$ , typical dBm (W)	$P_{Linear}$ , min. dBm (W)	$P_{sat} / P_{Linear}$	$P_{sat} / P_{Linear}$	$P_{sat}$ , typical dBm (W)	$P_{Linear}$ , min. dBm (W)
600 W	63.1 (2000)	60.1 (1000)	8,800/6,800	17,000/15,000	60.7 (1100)	57.7 (582)
800 W	64.1 (2570)	61.1 (1288)	10,000/8,000	18,000/17,000	61.7 (1500)	58.7 (733)
1000 W	65.1 (3200)	62.1 (1600)	16,000/14,000	32,600/31,000	62.7 (1800)	59.7 (923)

### 4 Module C-Band Outdoor PowerMAX System Power Specifications

SSPA Module Power Level	4 Module RF Output Power		AC Input Power (W)	Heat Load (Btu/hr)	3 Module Redundant RF Output Power	
	$P_{sat}$ , typical dBm (W)	$P_{Linear}$ , min. dBm (W)	$P_{sat} / P_{Linear}$	$P_{sat} / P_{Linear}$	$P_{sat}$ , typical dBm (W)	$P_{Linear}$ , min. dBm (W)
650 W	63.6 (2291)	60.6 (1148)	13,200/11,200	28,800/23,400	61.2 (1318)	58.2 (661)
800 W	64.5 (2818)	61.5 (1413)	16,000/14,000	35,000/29,400	62.1 (1622)	59.1 (813)

### 4 Module X-Band Outdoor PowerMAX System Power Specifications

SSPA Module Power Level	4 Module RF Output Power		AC Input Power (W)	Heat Load (Btu/hr)	3 Module Redundant RF Output Power	
	$P_{sat}$ , typical dBm (W)	$P_{Linear}$ , min. dBm (W)	$P_{sat} / P_{Linear}$	$P_{sat} / P_{Linear}$	$P_{sat}$ , typical dBm (W)	$P_{Linear}$ , min. dBm (W)
650 W	63.5 (2239)	60.5 (1122)	13,200/11,200	28,879/23,439	61.1 (1288)	58.1 (646)
800 W	64.4 (2754)	61.4 (1380)	16,000/14,000	34,880/29,438	62.0 (1585)	59.0 (794)

### 4 Module Ku-Band Outdoor PowerMAX System Power Specifications

SSPA Module Power Level	4 Module RF Output Power		AC Input Power (W)	Heat Load (Btu/hr)	3 Module Redundant RF Output Power	
	$P_{sat}$ , typical dBm (W)	$P_{Linear}$ , min. dBm (W)	$P_{sat} / P_{Linear}$	$P_{sat} / P_{Linear}$	$P_{sat}$ , typical dBm (W)	$P_{Linear}$ , min. dBm (W)
300 W	60.1 (1023)	57.1 (513)	11,000/8,400	22,600/19,600	57.7 (589)	54.7 (295)
400 W	61.3 (1350)	58.3 (676)	12,800/9,600	30,500/22,000	58.9 (776)	55.9 (389)
500 W	62.3 (1698)	59.3 (851)	16,000/12,000	38,000/27,000	60.0 (1000)	57.0 (501)

## Modular N+1 Soft-Fail Phase Combined GaN System

### 8 Module S-Band Outdoor PowerMAX System Power Specifications

SSPA Module Power Level	8 Module RF Output Power		AC Input Power (W)	Heat Load (Btu/hr)	7 Module Redundant RF Output Power	
	$P_{sat}$ , typical dBm (W)	$P_{Linear}$ , min. dBm (W)	$P_{sat} / P_{Linear}$	$P_{sat} / P_{Linear}$	$P_{sat}$ , typical dBm (W)	$P_{Linear}$ , min. dBm (W)
600 W	65.5 (3500)	62.5 (1800)	17,600/13,600	34,142/30,000	64.3 (2700)	61.3 (1350)
800 W	66.5 (4500)	63.5 (2240)	20,000/16,000	37,100/34,800	65.3 (3400)	62.3 (1700)
1000 W	67.5 (5600)	64.5 (2800)	32,000/28,000	65,280/65,000	66.3 (4300)	63.3 (2100)

### 8 Module C-Band Outdoor PowerMAX System Power Specifications

SSPA Module Power Level	8 Module RF Output Power		AC Input Power (W)	Heat Load (Btu/hr)	7 Module Redundant RF Output Power	
	$P_{sat}$ , typical dBm (W)	$P_{Linear}$ , min. dBm (W)	$P_{sat} / P_{Linear}$	$P_{sat} / P_{Linear}$	$P_{sat}$ , typical dBm (W)	$P_{Linear}$ , min. dBm (W)
650 W	66.4 (4365)	63.4 (2188)	26,400/22,400	57,750/46,880	65.2 (3311)	62.2 (1660)
800 W	67.3 (5370)	64.3 (2692)	32,000/28,000	69,755/58,875	66.1 (4074)	63.1 (2042)

### 8 Module X-Band Outdoor PowerMAX System Power Specifications

SSPA Module Power Level	8 Module RF Output Power		AC Input Power (W)	Heat Load (Btu/hr)	7 Module Redundant RF Output Power	
	$P_{sat}$ , typical dBm (W)	$P_{Linear}$ , min. dBm (W)	$P_{sat} / P_{Linear}$	$P_{sat} / P_{Linear}$	$P_{sat}$ , typical dBm (W)	$P_{Linear}$ , min. dBm (W)
650 W	66.3 (4266)	63.3 (2138)	26,400/22,400	57,759/46,879	65.1 (3236)	62.1 (1622)
800 W	67.2 (5248)	64.2 (2630)	32,000/28,000	69,755/58,875	66.0 (3981)	63.0 (1995)

### 8 Module Ku-Band Outdoor PowerMAX System Power Specifications

SSPA Module Power Level	8 Module RF Output Power		AC Input Power (W)	Heat Load (Btu/hr)	7 Module Redundant RF Output Power	
	$P_{sat}$ , typical dBm (W)	$P_{Linear}$ , min. dBm (W)	$P_{sat} / P_{Linear}$	$P_{sat} / P_{Linear}$	$P_{sat}$ , typical dBm (W)	$P_{Linear}$ , min. dBm (W)
300 W	62.8 (1905)	59.8 (955)	22,000/16,800	53,300/39,100	61.6 (1445)	58.6 (724)
400 W	64.0 (2512)	61.0 (1259)	25,600/19,200	61,000/43,560	62.8 (1905)	59.8 (955)
500 W	65.0 (3162)	62.0 (1585)	32,000/24,000	76,100/54,300	63.8 (2399)	60.8 (1202)

## Modular N+1 Soft-Fail Phase Combined GaN System

### 16 Module S-Band Outdoor PowerMAX System Power Specifications

SSPA Module Power Level	16 Module RF Output Power		AC Input Power (W)	Heat Load (Btu/hr)	15 Module Redundant RF Output Power	
	$P_{sat}$ , typical dBm (W)	$P_{Linear}$ , min. dBm (W)	$P_{sat} / P_{Linear}$	$P_{sat} / P_{Linear}$	$P_{sat}$ , typical dBm (W)	$P_{Linear}$ , min. dBm (W)
600 W	68.0 (6300)	65.0 (3100)	35,200/27,200	68,285/60,254	67.4 (5400)	64.4 (2700)
800 W	69.0 (7800)	66.0 (4000)	40,000/32,000	74,200/69,750	68.4 (6800)	65.4 (3400)
1000 W	70.0 (10000)	67.0 (5000)	64,000/56,000	130,000/129,000	69.4 (8600)	66.4 (4300)

### 16 Module C-Band Outdoor PowerMAX System Power Specifications

SSPA Module Power Level	16 Module RF Output Power		AC Input Power (W)	Heat Load (Btu/hr)	15 Module Redundant RF Output Power	
	$P_{sat}$ , typical dBm (W)	$P_{Linear}$ , min. dBm (W)	$P_{sat} / P_{Linear}$	$P_{sat} / P_{Linear}$	$P_{sat}$ , typical dBm (W)	$P_{Linear}$ , min. dBm (W)
650 W	69.1 (8128)	66.1 (4074)	52,800/44,800	115,517/93,757	68.5 (7079)	65.5 (3548)
800 W	70.0 (10000)	67.0 (5012)	64,000/56,000	139,511/117,751	69.4 (8710)	66.4 (4365)

### 16 Module X-Band Outdoor PowerMAX System Power Specifications

SSPA Module Power Level	16 Module RF Output Power		AC Input Power (W)	Heat Load (Btu/hr)	15 Module Redundant RF Output Power	
	$P_{sat}$ , typical dBm (W)	$P_{Linear}$ , min. dBm (W)	$P_{sat} / P_{Linear}$	$P_{sat} / P_{Linear}$	$P_{sat}$ , typical dBm (W)	$P_{Linear}$ , min. dBm (W)
650 W	69.0 (7643)	66.0 (3981)	52,800/44,800	115,517/93,757	68.4 (6918)	65.4 (3467)
800 W	70.0 (10000)	67.0 (5012)	64,000/56,000	139,511/117,751	69.3 (8511)	66.3 (4266)

### 16 Module Ku-Band Outdoor PowerMAX System Power Specifications

SSPA Module Power Level	16 Module RF Output Power		AC Input Power (W)	Heat Load (Btu/hr)	15 Module Redundant RF Output Power	
	$P_{sat}$ , typical dBm (W)	$P_{Linear}$ , min. dBm (W)	$P_{sat} / P_{Linear}$	$P_{sat} / P_{Linear}$	$P_{sat}$ , typical dBm (W)	$P_{Linear}$ , min. dBm (W)
300 W	65.4 (3467)	62.4 (1738)	44,000/33,600	106,500/78,500	64.8 (3020)	61.8 (1514)
400 W	66.6 (4571)	63.6 (2291)	51,200/38,400	122,000/87,000	66.0 (3981)	63.0 (1995)
500 W	67.6 (5754)	64.6 (2884)	64,000/48,000	152,300/108,750	67.0 (5012)	64.0 (2512)

## Modular N+1 Soft-Fail Phase Combined GaN System

### General Electrical Specifications

PARAMETER	NOTES	LIMITS	UNITS
Gain	Maximum, Ku-Band (Auto-Gain Off)	62	dB
	Maximum, Ku-Band (Auto-Gain On)	57	dB
	Maximum, S-, C- & X-Bands (Auto-Gain Off)	70	dB
	Maximum, S-, C- & X-Bands (Auto-Gain On)	65	dB
	Gain Flatness full band	± 1.0	dB
	Gain Slope per 40 MHz	± 0.3	dB/40 MHz
Gain Variation vs. Temperature	-40 °C to +60 °C	± 1.5	dB
Gain Adjustment	0.1 dB resolution	20	dB
Intermodulation Distortion	3 dB back off relative to P <sub>sat</sub>	-25	dBc
AM/PM Conversion	@ P <sub>Linear</sub>	< 1.0	°/dB
Spurious Harmonics	@ P <sub>Linear</sub>	-65	dBc
	@ P <sub>Linear</sub>	-50	dBc
Input VSWR		≤ 1.30 : 1	
Output VSWR		≤ 2.00 : 1	
Noise Figure	at maximum gain	10	dB
Group Delay	Linear	0.01	ns/MHz
	Parabolic	0.003	ns/MHz <sup>2</sup>
	Ripple	1.0	ns p-p
Noise Output	TX Band	-75	dBW/4 KHz
	RX Band	-100	dBW/4 KHz
Residual AM Noise	Offset frequency from carrier		
	1 Hz	-110	dBc/Hz
	10 Hz	-120	dBc/Hz
	100 Hz	-130	dBc/Hz
	1 KHz	-135	dBc/Hz
	10 KHz	-140	dBc/Hz
	100 KHz	-140	dBc/Hz
1 MHz	-140	dBc/Hz	
Residual Phase Noise	Offset frequency from carrier		
	10 Hz	-90	dBc/Hz
	100 Hz	-100	dBc/Hz
	1 KHz	-110	dBc/Hz
	10 KHz	-120	dBc/Hz
	100 KHz	-125	dBc/Hz
	1 MHz	-130	dBc/Hz
RF Leakage	@ 1m, with SSPA module removed	< 0.001	mW/cm <sup>2</sup>
True RF Power Detector	Range Accuracy	P <sub>sat</sub> to (P <sub>sat</sub> - 20) ± 0.75	dB dBm



### L-Band Input Option

The Outdoor PowerMAX system can be configured for L-Band Input operation. For optimum RF phase combining over the entire bandwidth of a communication amplifier system, the frequency translation part of the system must be separated from the phase combined loop. Therefore, systems with L-Band input are configured with a separate L-Band block up converter system that feeds the PowerMAX system.

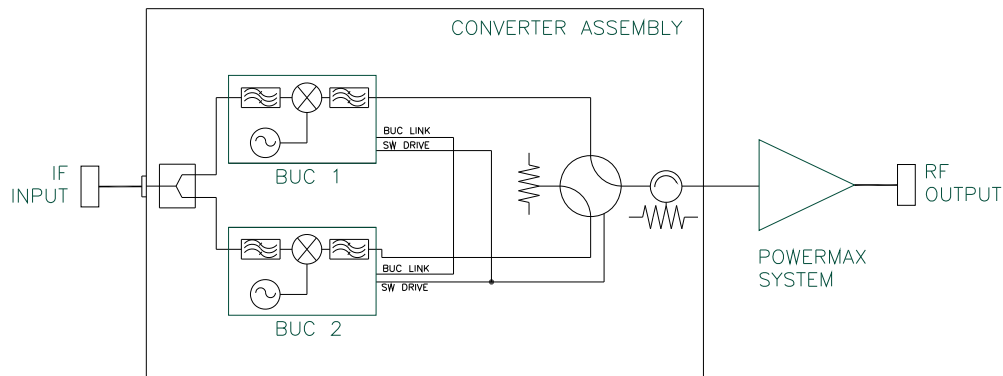

### Simplified Block Diagram, Redundant Converter Assembly with Outdoor Controller

The block up converter system is a 1:1 redundant block up converter assembly with internal redundancy control. The block up converters can be configured with internal or external reference oscillators. The Teledyne Paradise Datacom converter architecture allows a converter that is fitted with an internal reference oscillator to automatically detect and switch to an externally applied 10 MHz reference signal.

When a fault is detected in the online converter, the redundancy controller drives the switch to place the standby BUC online without user intervention.

If L-Band redundancy is not required, the system can be configured with a single thread block up converter.

# Outdoor PowerMAX

## Modular N+1 Soft-Fail Phase Combined GaN System

### System Part Number Configuration Matrix

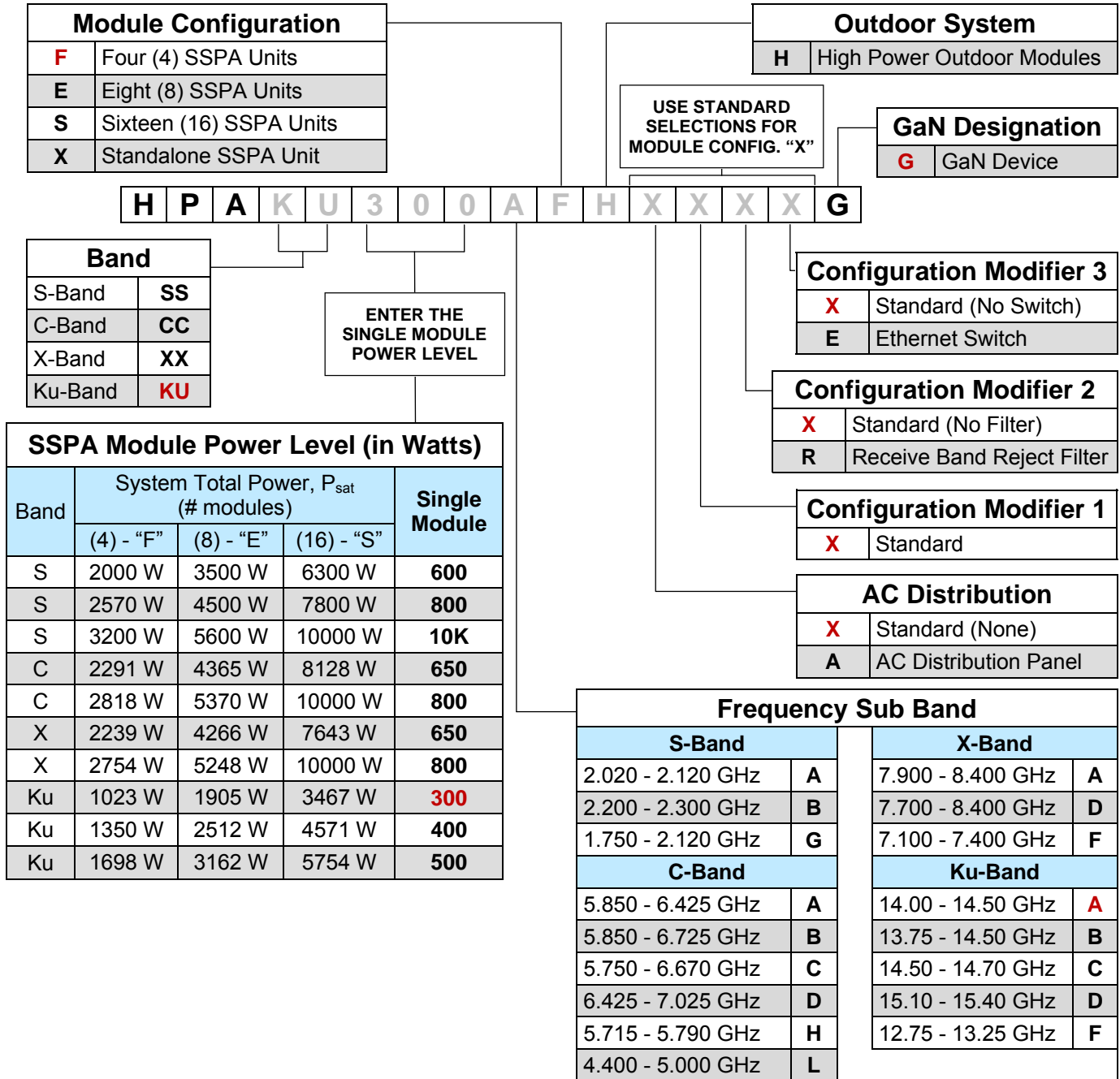

**Use and Disclosure of Data** — The items described herein are controlled by the U.S. Government and authorized for export only to the country of ultimate destination for use by the ultimate consignee or end-user(s) herein identified. They may not be resold, transferred, or otherwise disposed of, to any other country or to any person other than the authorized ultimate consignee or end-user(s), either in their original form or after being incorporated into other items, without first obtaining approval from the U.S. government or as otherwise authorized by U.S. law and regulations.

**Proprietary and Confidential** — The information contained in this document is the sole property of Teledyne Paradise Datacom. Any reproduction in part or as a whole without the written permission of Teledyne Paradise Datacom is prohibited.

Specifications are subject to change without notice.